

# XE 13 - 20<sup>ac</sup> Technical Data



# XE 13 - 20<sup>ac</sup> Technical Data

VDI 2198

Specification	1.1	Manufacturer		OM	OM	OM	
	1.2	Model designation		XE 13 <sup>3ac</sup>	XE 15 <sup>3ac</sup>	XE 16 <sup>3ac</sup>	
	1.3	Type of drive: Electric - Diesel - Petrol - GPL - Network Power (Electric)		Electric	Electric	Electric	
	1.4	Operation Type: Hand - Stand on - Driver seated		Driver Seated	Driver Seated	Driver Seated	
	1.5	Load Capacity	Q (t)	1.3	1.5	1.6	
	1.6	Load Baricenter Distance	c (mm)	500	500	500	
	1.8	Distance from axle centre to fork face	x (mm)	365 <sup>1) 2)</sup>	365 <sup>1) 2)</sup>	365 <sup>1) 2)</sup>	
	1.9	Wheel Base	y (mm)	1152	1260	1260	
Weights	2.1	Service Weight	kg	2819	2875	3072	
	2.2	Axle Weight with rated load	front / rear	kg	3585 / 534	3842 / 533	4117 / 555
	2.3	Axle Weight without load	front / rear	kg	1309 / 1510	1313 / 1562	1417 / 1655
Wheels and Tyres	3.1	Tyres SE = superelastic - PN = pneus		SE / SE <sup>3)</sup>	SE / SE <sup>3)</sup>	SE / SE <sup>3)</sup>	
	3.2	Front tyres size		18x7-8 <sup>3)</sup>	18x7-8 <sup>3)</sup>	18x7-8 <sup>3)</sup>	
	3.3	Rear tyres size		15x4.5-8 <sup>3)</sup>	15x4.5-8 <sup>3)</sup>	15x4.5-8 <sup>3)</sup>	
	3.5	Tyres number front / rear (x = drive)		2x / 2	2x / 2	2x / 2	
	3.6	Front track width	b10 (mm)	932 <sup>4)</sup>	932 <sup>4)</sup>	932 <sup>4)</sup>	
	3.7	Rear track width	b11 (mm)	168	168	168	
Dimensions and Overall Sizes	4.1	Lifting assembly tilting	forward/backward	Grad	3° / 9° <sup>5)</sup>	3° / 9° <sup>5)</sup>	
	4.2	Mast minimum overall height		h1 (mm)	2210 <sup>6)</sup>	2210 <sup>6)</sup>	
	4.3	Free height		h2 (mm)	150	150	
	4.4	Lift height		h3 (mm)	3330	3330	
	4.5	Mast maximum overall height		h4 (mm)	3905 <sup>7)</sup>	3905 <sup>7)</sup>	
	4.7	Overheadguard height		h6 (mm)	2139 <sup>8)</sup>	2024 <sup>11)</sup>	2139 <sup>8)</sup>
	4.8	Seat Height		h7 (mm)	1054	939	1054
	4.12	Drawbar height		h10 (mm)	523	523	523
	4.19	Overall Length		l1 (mm)	2726 <sup>1) 2)</sup>	2834 <sup>1) 2)</sup>	2834 <sup>1) 2)</sup>
	4.20	Overall Length including fork arms spessore forche		l2 (mm)	1726 <sup>1) 2)</sup>	1834 <sup>1) 2)</sup>	1834 <sup>1) 2)</sup>
	4.21	Overall width		b1/b2 (mm)	1067 <sup>9)</sup>	1067 <sup>9)</sup>	1067 <sup>9)</sup>
	4.22	Fork arms dimension		s/e/l (mm)	40/80/1000	40/80/1000	40/80/1000
	4.23	Fork carriage in compliance with DIN 15173 Classe / Form A, B			2A	2A	2A
	4.24	Fork carriage width		b3 (mm)	1040 <sup>10)</sup>	1040 <sup>10)</sup>	1040 <sup>10)</sup>
	4.31	Mast ground clearance (with load)		m1 (mm)	95 <sup>6)</sup>	95 <sup>6)</sup>	95 <sup>6)</sup>
	4.32	Chassis ground clearance (with load) [middle of the chassis]		m2 (mm)	104	104	104
	4.33	Aisle width with pallet 1000x1200 and fork arm pitch 1200		Ast (mm)	3052 <sup>1) 2)</sup>	3160 <sup>1) 2)</sup>	3160 <sup>1) 2)</sup>
	4.34	Aisle width with pallet 800x1200 and fork arm pitch 800		Ast (mm)	3176 <sup>1) 2)</sup>	3284 <sup>1) 2)</sup>	3284 <sup>1) 2)</sup>
	4.35	Turning radius		Wa (mm)	1361	1469	1469
	4.36	Turning point minimum distance from the truck center line		b13 (mm)	-	-	-
Performance	5.1	Drive speed	with / without load	km/h	14 / 14	14 / 14	14 / 14
	5.2	Lifting speed	with / without load	m/s	0,51 / 0,57	0,51 / 0,57	0,51 / 0,57
	5.3	Lowering speed	with / without load	m/s	0,52 / 0,41	0,54 / 0,41	0,54 / 0,41
	5.5	Drawbar pull tractive effort (S2 60 min)	with / without load	N	2150/2100	2150 / 2100	2100 / 2050
	5.6	Drawbar pull tractive effort (S2 5 min)	with / without load	N	9250/8950	9250 / 8950	9250 / 8900
	5.7	Gradeability (S2 30 min)	with / without load	%	9,5/13,5	9 / 13	8 / 12
	5.8	Maximum gradeability (S2 5 min)	with / without load	%	23 / 33	21,5 / 32	20 / 29,5
	5.9	Acceleration time (10 m)	with / without load	s	4,1/3,8	4,2 / 3,9	4,3 / 4
	5.10	Service brake			Electric/Mechanic	Electric/Mechanic	Electric/Mechanic
Engine	6.1	Drive motor, power S2 60 min	kW	4 x 2	4 x 2	4 x 2	
	6.2	Lifting motor, power S3 15%	kW	9	9	9	
	6.3	Battery in compliance with DIN 43531/35/36 A, B, C, NO		43531A	43531A	43531A	
	6.4	Voltage, Battery Capacity K5	V / Ah	48 / 465	48 / 480 <sup>12)</sup>	48 / 640	
	6.5	Battery weight	kg	749	780 <sup>12)</sup>	970	
	6.6	Power consumption according to VDI cycle	kWh/h	-	-	-	
Others	8.1	Drive control type		Chopper	Chopper	Chopper	
	8.2	Service pressure for attachments	bar	160	160	160	
	8.3	Oil flow rate for attachment (max available)	l/min	30	30	30	
	8.4	Noise at operator's ear	dB (A)	<70	<70	<70	
	8.5	Drawbar, Modell / Type DIN		-	-	-	

The values presented are to be taken as indicative and not binding; they refer to the standard equipment

XE13<sup>3</sup> XE15<sup>3</sup> XE16<sup>3</sup> XE18<sup>3</sup> XE20<sup>3</sup>

- 1) With side shif + 17 mm
- 2) With Triplex masts TX + 20 mm (+22mm for XE 20)
- 3) For alternative tyres see table
- 4) 945 mm with wheels 200/50-10 and 875mm with 18x5x12 1/8" (vulkolan)
- 5) Sx mast with h3 ≥ 4530 mm. All Duplex and Triplex DX and TX
- 6) For all configuration
- 7) 6 rollers fork plate 3973 mm
- 8) h6 = 2080 mm for lowered cab

9) 1150.5 mm with wheels 200/50-10 e 1002mm con 18x5x12 1/8" (vulkolan)

- 10) With S.L.I. = 980 mm
- 11) h6 = 1980 mm for lowered cab
- 12) Battery optional (capacity/weight): 400Ah / 709±5%Kg; 460Ah / 765±5%Kg; 500Ah / 780±5%Kg.
- 13) Battery optional (capacity/weight): 575Ah / 915±5%Kg; 625Ah / 930±5%Kg.
- 14) Only for 6 rollers fork plate
- 15) Based on 60 cycles/h

OM	OM	OM	OM	OM	OM	1.1
XE 18 <sup>3ac</sup>	XE 20 <sup>3ac</sup>	XE 15 <sup>3ac</sup>	XE 16 <sup>3ac</sup>	XE 18 <sup>3ac</sup>	XE 20 <sup>3ac</sup>	1.2
Electric	Electric	Electric	Electric	Electric	Electric	1.3
Driver Seated	Driver Seated	Driver Seated	Driver Seated	Driver Seated	Driver Seated	1.4
1.8	2.0	1.5	1.6	1.8	2.0	1.5
500	500	500	500	500	500	1.6
370 <sup>1) 2)</sup>	380 <sup>1) 2)</sup>	365 <sup>1) 2)</sup>	365 <sup>1) 2)</sup>	370 <sup>1) 2)</sup>	380 <sup>1) 2)</sup>	1.8
1368	1513	1280	1280	1388	1498	1.9
3067	3240	2852	3090	3045	3250	2.1
4369 / 498	4746 / 494	3809 / 543	4170 / 520	4337 / 508	4727 / 523	2.2
1431 / 1636	1582 / 1658	1295 / 1557	1455 / 1635	1416 / 1629	1552 / 1698	2.3
SE / SE <sup>3)</sup>	SE / SE <sup>3)</sup>	SE / SE <sup>3)</sup>	SE / SE <sup>3)</sup>	SE / SE <sup>3)</sup>	SE / SE <sup>3)</sup>	3.1
18x7-8 <sup>3)</sup>	200/50-10 <sup>3)</sup>	18x7-8 <sup>3)</sup>	18x7-8 <sup>3)</sup>	18x7-8 <sup>3)</sup>	200/50-10 <sup>3)</sup>	3.2
15x4.5-8 <sup>3)</sup>	140/55-9 <sup>3)</sup>	15x4.5-8 <sup>3)</sup>	15x4.5-8 <sup>3)</sup>	15x4.5-8 <sup>3)</sup>	140/55-9 <sup>3)</sup>	3.3
2x / 2	2x / 2	2x / 2	2x / 2	2x / 2	2x / 2	3.5
932 <sup>4)</sup>	945 <sup>4)</sup>	932 <sup>4)</sup>	932 <sup>4)</sup>	932 <sup>4)</sup>	945 <sup>4)</sup>	3.6
168	176	874	874	874	873	3.7
3° / 9° <sup>5)</sup>	3° / 9° <sup>5)</sup>	3° / 9° <sup>5)</sup>	3° / 9° <sup>5)</sup>	3° / 9° <sup>5)</sup>	3° / 9° <sup>5)</sup>	4.1
2210 <sup>6)</sup>	2260 <sup>6)</sup>	2210 <sup>6)</sup>	2210 <sup>6)</sup>	2210 <sup>6)</sup>	2260 <sup>6)</sup>	4.2
150	150	150	150	150	150	4.3
3330	3350	3330	3330	3330	3350	4.4
3973	4046 <sup>14)</sup>	3905 <sup>7)</sup>	3905 <sup>7)</sup>	3973	4046 <sup>14)</sup>	4.5
2024 <sup>11)</sup>	2024 <sup>11)</sup>	2024 <sup>8)</sup>	2139 <sup>12)</sup>	2024 <sup>8)</sup>	2024 <sup>8)</sup>	4.7
939	939	939	1054	939	939	4.8
523	523	523	523	523	523	4.12
2947 <sup>1) 2)</sup>	3102 <sup>1) 2)</sup>	2910 <sup>1) 2)</sup>	2910 <sup>1) 2)</sup>	3018 <sup>1) 2)</sup>	3143 <sup>1) 2)</sup>	4.19
1947 <sup>1) 2)</sup>	2102 <sup>1) 2)</sup>	1910 <sup>1) 2)</sup>	1910 <sup>1) 2)</sup>	2018 <sup>1) 2)</sup>	2143 <sup>1) 2)</sup>	4.20
1067 <sup>9)</sup>	1150 <sup>9)</sup>	1067 <sup>9)</sup>	1067 <sup>9)</sup>	1067 <sup>9)</sup>	1150 <sup>9)</sup>	4.21
45/100/1000	45/100/1000	40/80/1000	40/80/1000	45/100/1000	45/100/1000	4.22
2A	2A	2A	2A	2A	2A	4.23
1040 <sup>10)</sup>	1040 <sup>10)</sup>	1040 <sup>10)</sup>	1040 <sup>10)</sup>	1040 <sup>10)</sup>	1040 <sup>10)</sup>	4.24
95 <sup>6)</sup>	95 <sup>6)</sup>	95 <sup>6)</sup>	95 <sup>6)</sup>	95 <sup>6)</sup>	95 <sup>6)</sup>	4.31
104	104	104	104	104	104	4.32
3268 <sup>1) 2)</sup>	3427 <sup>1) 2)</sup>	3246 <sup>1) 2)</sup>	3246 <sup>1) 2)</sup>	3359 <sup>1) 2)</sup>	3480 <sup>1) 2)</sup>	4.33
3392 <sup>1) 2)</sup>	3552 <sup>1) 2)</sup>	3432 <sup>1) 2)</sup>	3432 <sup>1) 2)</sup>	3550 <sup>1) 2)</sup>	3677 <sup>1) 2)</sup>	4.34
1577	1722	1667	1667	1780	1895	4.35
-	-	407	407	442	477	4.36
14 / 14	14 / 14	14 / 14	14 / 14	14 / 14	14 / 14	5.1
0,4 / 0,57	0,4 / 0,48	0,51 / 0,57	0,51 / 0,57	0,4 / 0,57	0,4 / 0,48	5.2
0,54 / 0,41	0,48 / 0,35	0,54 / 0,41	0,54 / 0,41	0,54 / 0,41	0,48 / 0,35	5.3
2100 / 2050	2050 / 2050	2150 / 2100	2100 / 2050	2100 / 2050	2050 / 2050	5.5
9300 / 8950	9400 / 9000	9250 / 8950	9250 / 8900	9300 / 8950	9400 / 9000	5.6
8 / 12	7,5 / 11,5	9 / 13	8 / 12	8 / 12	7,5 / 11,5	5.7
19,5 / 30	18 / 28,5	21,5 / 32	20 / 29,5	19,5 / 30	18 / 28,5	5.8
4,5 / 4,1	4,6 / 4,2	4,2 / 3,9	4,3 / 4	4,5 / 4,1	4,6 / 4,2	5.9
Electric/Mechanic	Electric/Mechanic	Electric/Mechanic	Electric/Mechanic	Electric/Mechanic	Electric/Mechanic	5.10
4 x 2	4 x 2	4 x 2	4 x 2	4 x 2	4 x 2	6.1
9	9	9	9	9	9	6.2
43531A	43531A	43531A	43531A	43531A	43531A	6.3
48 / 600 <sup>13)</sup>	48 / 750	48 / 480 <sup>11)</sup>	48 / 640	48 / 600 <sup>13)</sup>	48 / 750	6.4
930 <sup>13)</sup>	1055	780 <sup>11)</sup>	970	930 <sup>13)</sup>	1055	6.5
-	6,2 <sup>15)</sup>	-	-	-	6,21 <sup>5)</sup>	6.6
Chopper	Chopper	Chopper	Chopper	Chopper	Chopper	8.1
160	160	160	160	160	160	8.2
30	30	30	30	30	30	8.3
<70	<70	<70	<70	<70	<70	8.4
-	-	-	-	-	-	8.5

**XE15 XE16 XE18 XE20**

- 1) With side shift + 17 mm  
2) With Triplex masts TX + 20 mm (+22mm for XE 20)  
3) For alternative tyres see table  
4) 945 mm with wheels 200/50-10 and 875mm with 18x5x12 1/8" (vulkolan)  
5) Sx mast with h3 ≥ 4530 mm. All Duplex e Triplex DX e TX  
6) For all configuration  
7) 6 roller fork plate: 3973 mm  
8) h6= 1980 mm for lowered cab  
9) 1150.5 mm with wheels 200/50-10 and 1002mm with 18x5x12 1/8" (vulkolan)

- 10) With S.L.I. = 980 mm  
11) Battery optional (capacity/weight): 400Ah / 709±5%Kg; 460Ah / 765±5%Kg; 500Ah / 780±5%Kg.  
12) h6= 2080 mm for lowered cab  
13) Battery optional (capacity/weight): 575Ah / 915±5%Kg; 625Ah / 930±5%Kg  
14) Only for 6 rollers fork plate  
15) Based on 60 cycles/h

Safety distance= 200 mm

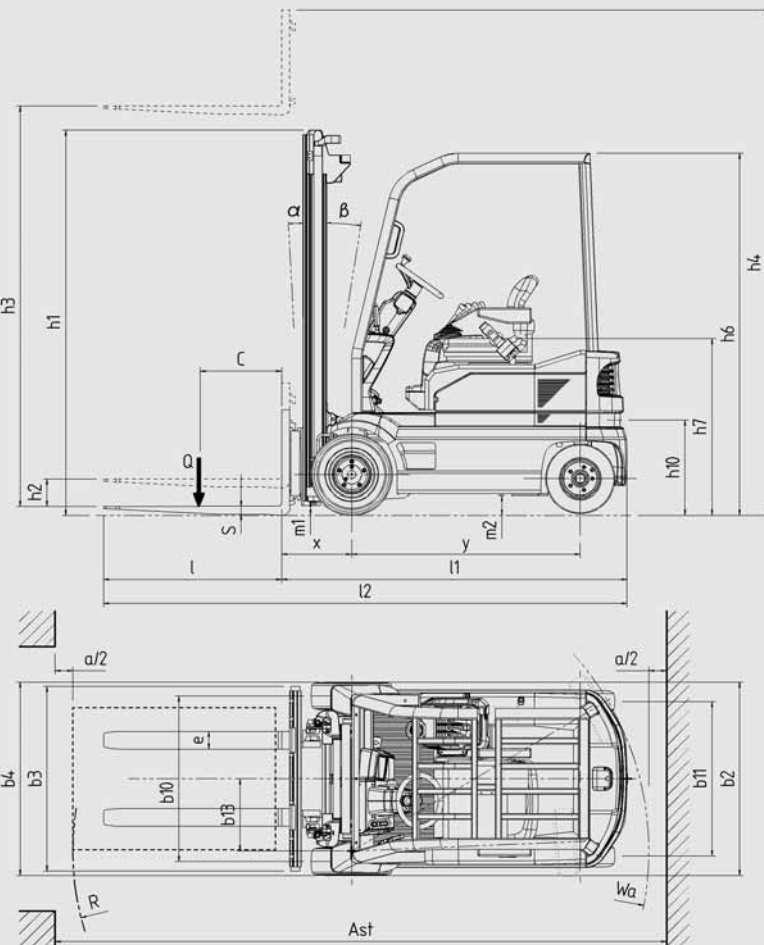
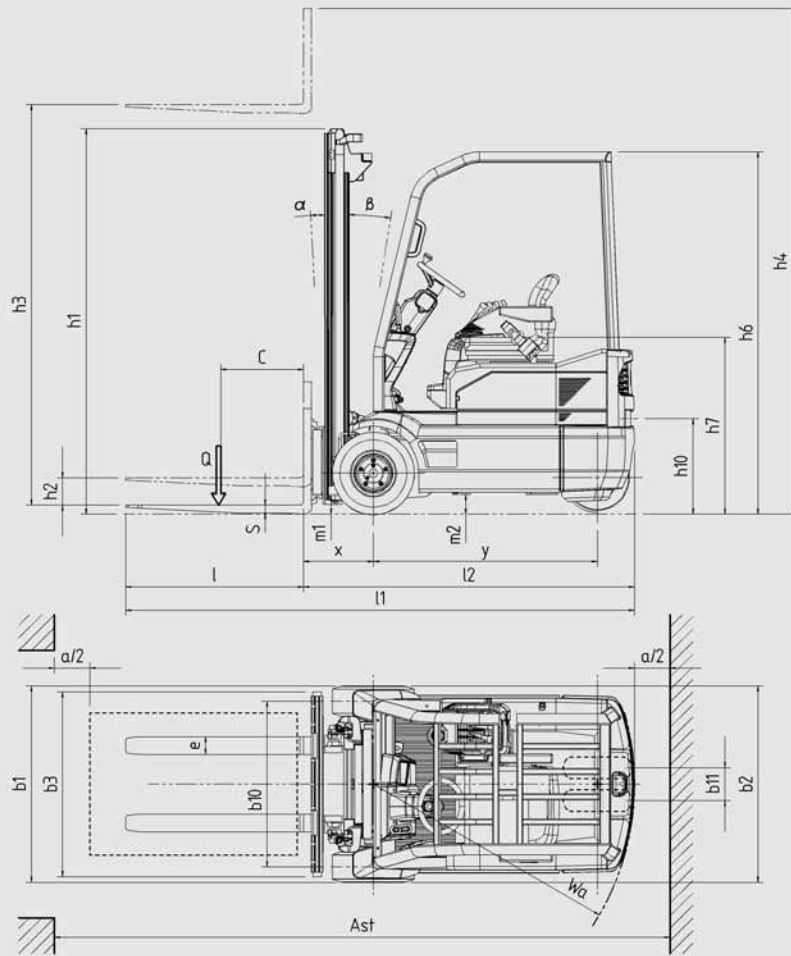

## LIFT MAST SPECIFICATIONS

		Standard (Simplex)					Duplex					Triplex						
XE13 <sup>3</sup> XE15 <sup>3</sup> - XE15 XE16 <sup>3</sup> - XE16 4 Rollers Fork Carriage ( * )	Lift Height $h_3$ mm	3330	3630	4030	4530	5030	2875	2975	3275	3575**	3975	4170	4470***	4770	5220**	5770	6370	6970
	Minimum Overall Height $h_1$ mm	2210	2360	2560	2810	3060	1960	2010	2160	2310	2510	1960	2060	2160	2310	2560	2760	2960
	Maximum Overall Height $h_4$ mm	3905	4205	4605	5105	5605	3450	3550	3850	4150	4550	4745	5045	5345	5795	6345	6945	7545
	Free Lift $h_2$ mm	150	150	150	150	150	1312	1362	1512	1662	1862	1312	1412	1512	1662	1912	2112	2312
XE18 <sup>3</sup> - XE18 6 Rollers Fork Carriage	Lift Height $h_3$ mm	3330	3630	4030	4530	5030	2875	2975	3275	3575**	3975	4170	4470***	4770	5220**	5770	6370	6970
	Minimum Overall Height $h_1$ mm	2210	2360	2560	2810	3060	1960	2010	2160	2310	2510	1960	2060	2160	2310	2560	2760	2960
	Maximum Overall Height $h_4$ mm	3973	4273	4673	5173	5673	3543	3643	3943	4243	4643	4838	5138	5438	5888	6438	7038	7638
	Free Lift $h_2$ mm	150	150	150	150	150	1312	1362	1512	1662	1862	1312	1412	1512	1662	1912	2112	2312
XE20 <sup>3</sup> - XE20 6 Rollers Fork Carriage	Lift Height $h_3$ mm	3350	3650	4050	4550	5050	-	2970	3270	3570	3970	-	4465	4765	5215	5665	6265	6865
	Minimum Overall Height $h_1$ mm	2260	2410	2610	2860	3110	-	2010	2160	2310	2510	-	2060	2160	2310	2460	2660	2860
	Maximum Overall Height $h_4$ mm	4046	4346	4746	5246	5746	-	3646	3946	4246	4646	-	5156	5456	5906	6356	6956	7556
	Free Lift $h_2$ mm	150	150	150	150	150	-	1445	1595	1745	1945	-	1495	1595	1745	1895	2095	2295

( \* ) with optional fork carriage (6 rollers)

$h_4 = h_4 + 68$  mm (SX)

$h_4 = h_4 + 93$  mm (DX-TX)

$h_2 = h_2 - 93$  mm (DX-TX)

\*\*  $h_1 = 2260$  mm for lowered cab

\*\*\*  $h_1 = 2010$  mm for lowered cab

## WHEELS

Type	Superelastic		Pneumatic		Vulkan / Superelastic	
	Front	Rear	Front	Rear	Front (Vulkan)	Rear (SE)
XE13 <sup>3ac</sup> XE15 <sup>3ac</sup> XE15 <sup>ac</sup> XE16 <sup>3ac</sup> XE16 <sup>ac</sup>	-	-	18x7-8/16 (SX-DX)	15x4.5-8/12 (SX-DX)	18x5x12 1/8"	15x4.5-8 (S.E. white)
XE18 <sup>3ac</sup> XE18 <sup>ac</sup>	18x7-8 (SX-DX) 200/50-10 (TX)	15x4.5-8	18x7-8/16 (SX-DX)	15x4.5-8/12 (SX-DX)	18x5x12 1/8"	15x4.5-8 (S.E. white)
XE 20 <sup>3ac</sup> XE 20 <sup>ac</sup>	200/50-10	140/55-9	-	-	18x5x12 1/8"	140/55-9 (S.E. white)

## XE 13 - 20<sup>ac</sup>

### Electric counterbalanced fork lift trucks



The new XE 13-20<sup>ac</sup> is the latest expression of OM know-how in designing and building electric forklift trucks. This range includes three and four wheels models from 1.3 to 2 tons.

Thanks to the optimal spaces allocation and components layout, this range of trucks is perfectly fit to work even in narrow environments achieving also the best comfort for the operator, who can be more productive: the standard Grammer MSG 20 seat is able to deaden any vibration to reduce the operator toil. As option the armrest equipped extra comfort seat MSG 65 by Grammer can be installed as well. In the cockpit everything is within reach: the LCD display reports all the needed information: speed, steering wheels position, hour meter, battery charge indicator and diagnostics data. The hydraulic levers are comfortably placed by the operator right side, increasing the precision and safety of any mast movement.

On the XE 13-20<sup>ac</sup> the two engines, the brakes and the transmission are integrated in a front axle and protected against dust and water with an IP 54 grade. This focused design integration allows keeping the noise level always low and lower than 70 dB.

The wet oil disk brakes assisting a powerful regenerative braking system is the best technical solution for braking effect, modulability and being maintenance free, service costs.

The new 48V AC front traction unit allows the best performance: energy efficiency, acceleration and gradeability are among the best in its class.

Thanks to the electronic controller, designed basing on the latest technologies for power circuits, the maximum part of the current coming from the battery is effectively routed to the engines with almost no loss in heat.

Driver can easily choose among three different preset performance profiles affecting both traction and lifting: maximum performance or battery endurance, on the display.

The new XE 13-20<sup>ac</sup> is covered by the OM INTRINSIC SAFETY PROGRAM dedicated to enforce the highest level of safety in any working condition. OMISP includes: Automatic speed reduction in corners, Mast Safety System -mast locked when the operator is not seated and electronic differential.

These trucks retain their direction even when braking on problematic floors. The XE13-20 trucks range is in compliance with ISO 3691-1 standards.

The AC lifting is powered by a 48V-9kW engine. The batteries, DIN standard compliant, range from 460 Ah to 750Ah.

Simplex, Duplex and Triplex masts are optionally available with lifting heights up to 6900mm.

Options: Manual fwd/rev switch, sidershifter, seats, lights, wheels, different versions of closed cabs

OM continually improves products as new technologies and components become available.

OM therefore, reserves the rights to change specifications without prior notice.



OM Carrelli Elevatori S.p.A.  
Viale A. De Gasperi, 7  
I-20020 Lainate (MI)  
Tel.: +39(02)937 65-1  
Fax: +39(02)937 65-450  
[www.om-mh.com](http://www.om-mh.com)