

WORLD PREMIERE!



EUROCOMPACT FL02/FL03
WHEN LIGHTNESS STRIKES

WORLD PREMIERE!



Time is money

Savings are made on both with the **innovative Clever Coupling technology**.



More flexibility

With the flat deck, the FL 02 and FL 03 provide **significantly more loading height**.



Light and strong

The new EuroCompact models make a convincing case with **up to 20% more payload**.



Maneuverability

The new steering concept **improves manoeuvring and minimises wear**.



YOUR ADVANTAGES AT A GLANCE

LOADING HEIGHT

The optimised flat bed deck facilitates an **increased loading height** with a lower weight.

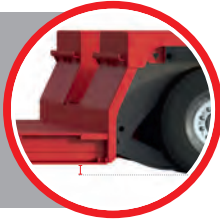

EMPTY WEIGHT

With a bridge height of only 200 mm, the empty weight of the FL02 is only 12,650 kg.

Compared to its predecessor, it thus has a payload **increase of 20%**.



WORLD PREMIERE!

FLEXIBILITY

High degree of flexibility in freight transport thanks to the prismatic-shaped excavator arm recess.

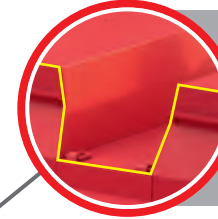

OPERATING CONCEPT

Intuitive handling of the low-bed semi-trailer with a **new operating concept**.



STEERING

The new steering concept ensures minimal wear and **excellent manoeuvrability**.



AXLE COMPENSATION

The high axle compensation of **650 millimetres** makes negotiating obstacles child's play.

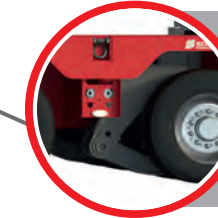

SAFETY

Numerous lashing points guarantee a **high level of safety**.



COUPLING

SCHEUERLE **Clever Coupling** for **fast coupling and uncoupling** – also off-road.

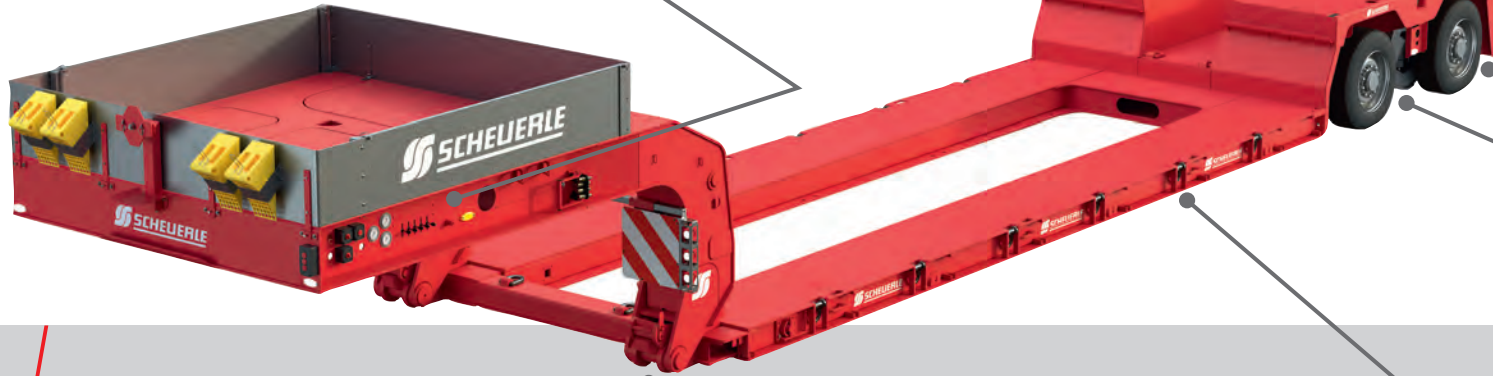
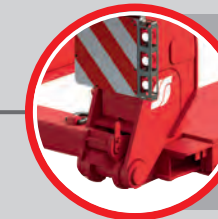

NEVER STOP IMPROVING

It's not about being better than others, it's all about becoming even better. This is what counts! In sport as on the roads!

The **new EuroCompact FL02 and FL03** models stand for lightness with maximum payload, comfort and quality. However, this is not everything.

With intelligent equipment features, the EuroCompact FL02 and FL03 models have been enhanced in order to make your fleet more economical, safer and more efficient.

EuroCompact FL02

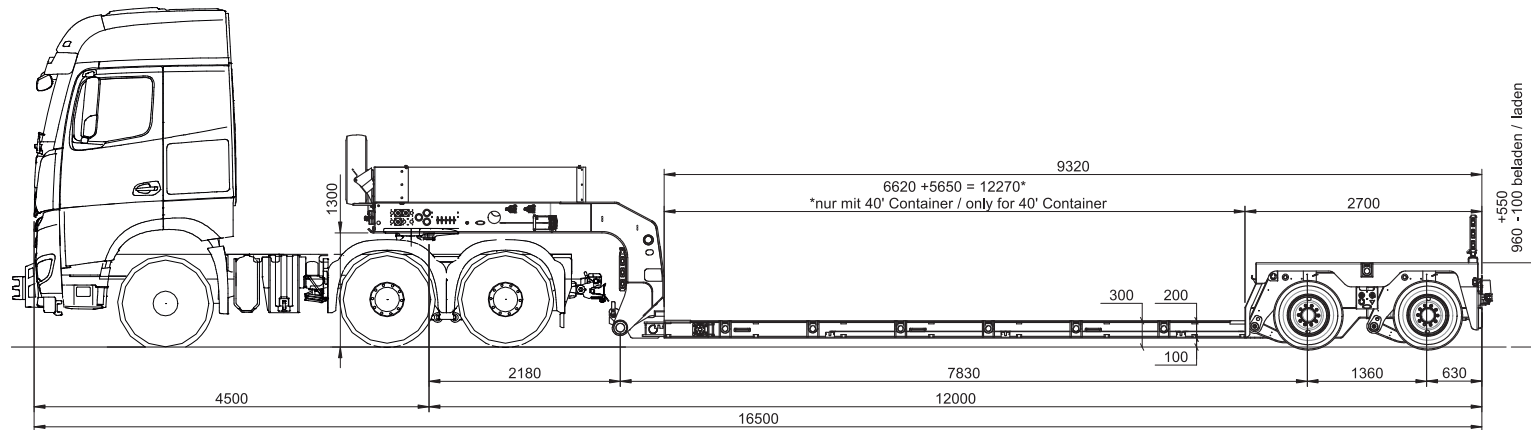

EuroCompact FL03

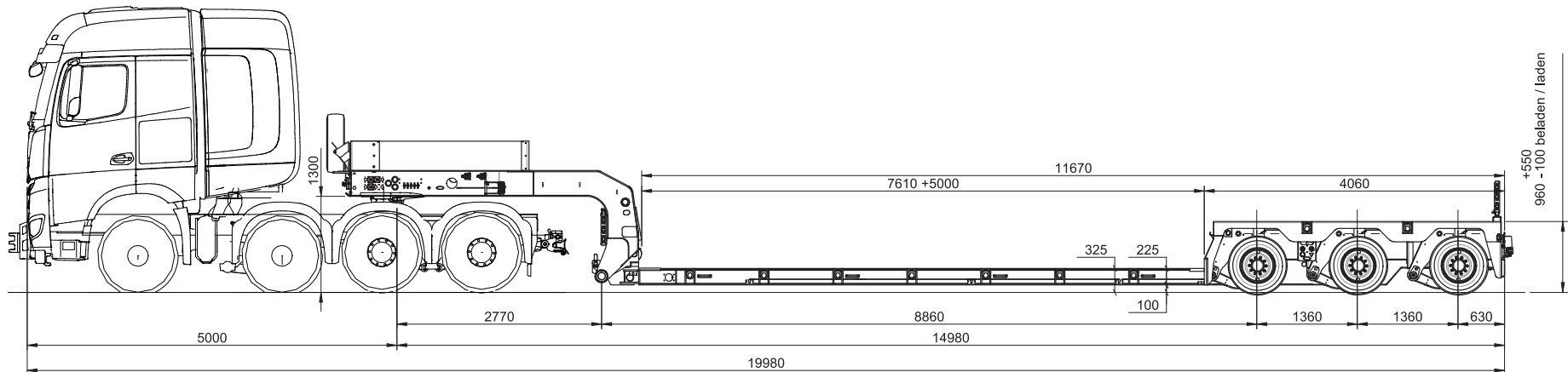

SAFE, ERGONOMICAL AND QUICK

**Maximum possible safety
for your drivers.**

Ergonomics and **safety** characterise the **EuroCompact FL02** and **FL03**. For example, the **multi-coupler** and **power sockets** are mounted on the outside of the gooseneck thus making it easier for the driver to access them.

In order to complete the coupling procedure, it is not necessary to access the deck or reach inside the gooseneck. Work accidents are thus avoided, the coupling procedure is accelerated and time-savings are ensured.



THE SAME BUT DIFFERENT

For transporting:

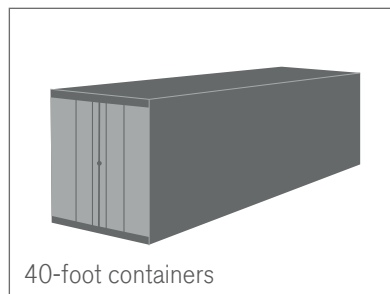
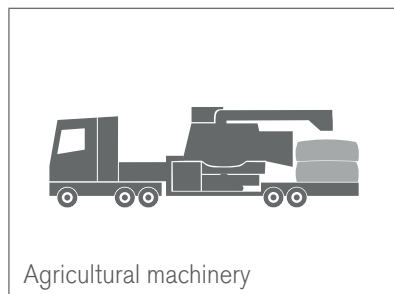
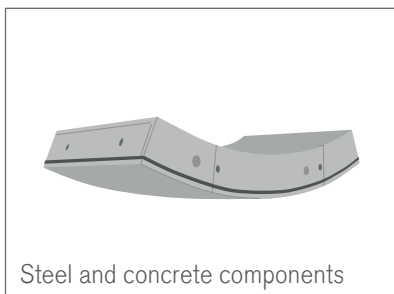
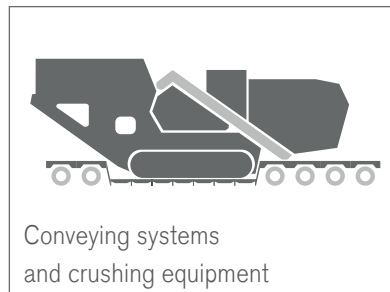
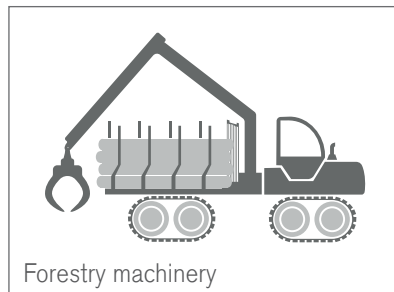
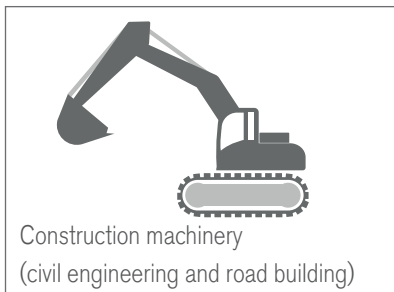

TECHNICAL DATA

EuroCompact	FL02	FL03
Payload	ca. 36 t	ca. 48 t
Speed (max)	80 km/h	80 km/h
Axle compensation	650 mm	650 mm
Axle type	Floating Axle	Floating Axle
Loading height* <small>*at 100 mm ground clearance</small>	300 mm	325 mm
Type of deck	Telescopic flat bed deck	Telescopic flat bed deck
Tyres	245/70 R17.5	245/70 R17.5

*technical changes reserved

SCHEUERLE CLEVER COUPLING

**Even the best drivers
can also use some support.**

In certain situations, such as on uneven ground, drivers often face the challenge of not being able to connect the low-bed semi-trailer to the gooseneck. With the all-terrain hook coupling from SCHEUERLE, this is now a thing of the past!

Thanks to the unique shape of the hook coupling, the deck can be quickly and safely connected to the gooseneck. Whether off or on-road
- **the EuroCompact can go everywhere!**

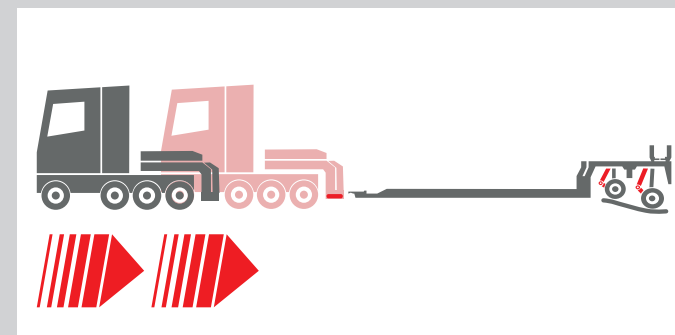

TII Sales
*Transporter Industry International
Sales GmbH & Co. KG
Otto-Rettenmaier-Str. 15
74629 Pfedelbach
Germany*

*Tel.: +49 (0) 7941 691 200
Fax: +49 (0) 7941 691 400
E-Mail: info@tii-sales.com*

www.tii-group.com